

or pair of ranges shall be grouped as close as possible to the distribution pipe on the next upstream range row to the rectangular area (see Figures 23 and 25);

- b) In the case of gridded configurations where ranges run parallel to the ridge of a roof having a slope greater than 6°, or along bays formed by beams greater than 1,0 m deep, the far side of the area shall have a length L parallel to the ranges, such that L is greater than or equal to two times the square root of the area of operation;
- c) In the case of all other gridded configurations the far side of the area shall have a length L parallel to the ranges, such that L is greater than or equal to 1,2 times the square root of the area of operation.

13.4.3.2 Hydraulically most favourable location

The area of operation shall be as near as possible square and as follows:

- a) In the case of terminal and looped configurations, the area shall where possible include sprinklers on one distribution pipe only. The number of sprinklers calculated to be operating on ranges, or pairs of ranges in end-centre installations, shall be located on each range or pair of ranges at the hydraulically most favourable location. Sprinklers not forming a full range or pair of ranges shall be located on the next range row at the hydraulically closest locations (see Figures 24 and 26).
- b) In the case of gridded configurations, the area shall be located on ranges at the hydraulically most favourable location. Sprinklers not forming a full range length shall be located on the next range row at the hydraulically closest locations (see Figure 23).

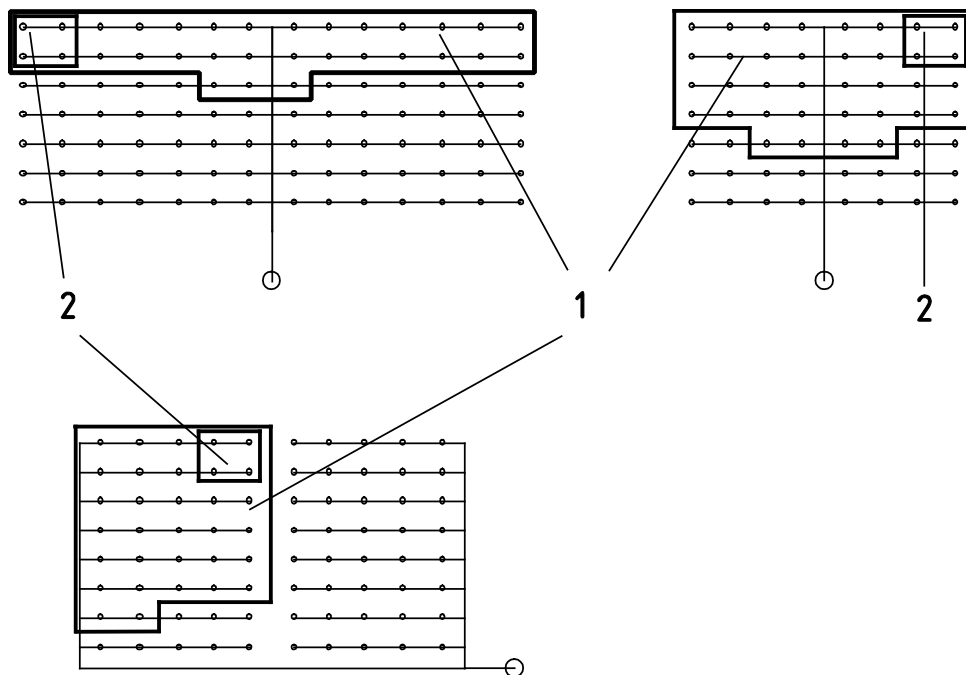

- Key**
- 1 most unfavourable area
 - 2 four sprinkler under consideration'

Figure 23 — Most unfavourable areas of operation in one-sided and two-sided pipe layouts

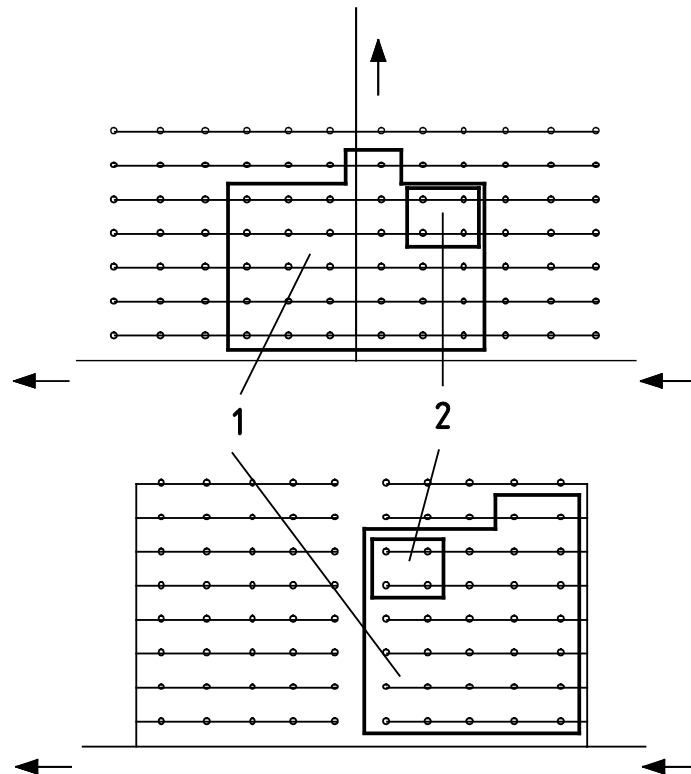

Key

- 1 most favourable area
- 2 four sprinkler under consideration'

Figure 24 — Most favourable areas of operation in one-sided and two-sided pipe layouts

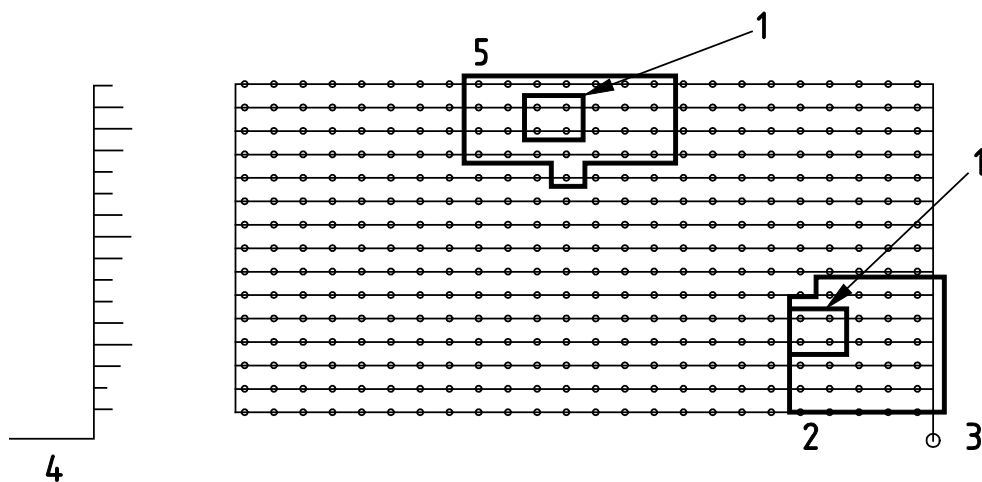

Key

- 1 four sprinklers under consideration
- 2 most favourable area
- 3 riser
- 4 elevation
- 5 most unfavourable area

Figure 25 — Most favourable and unfavourable areas of operation in gridded pipe layout

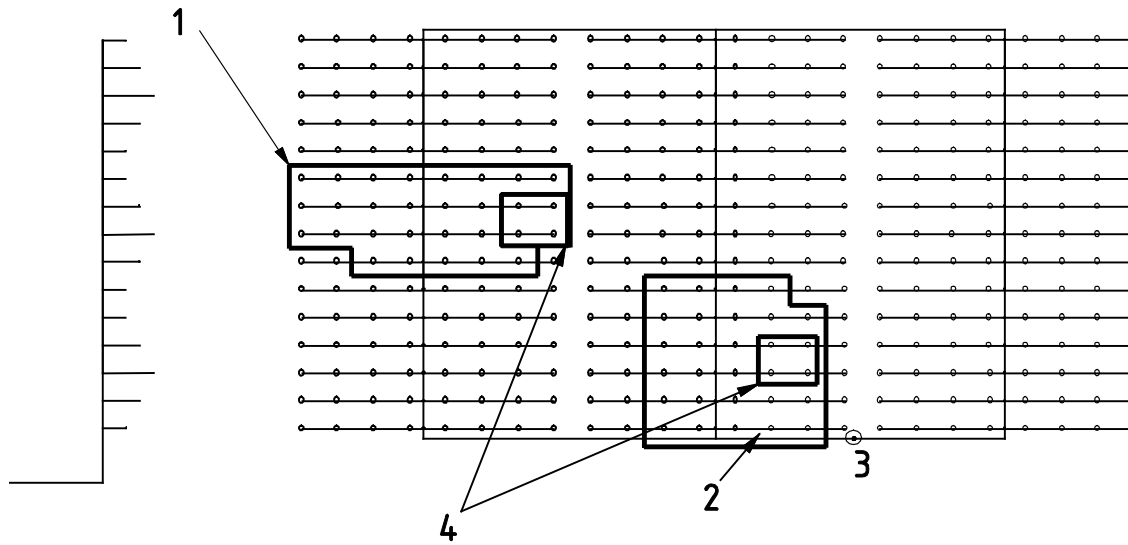

Key

- 1 most unfavourable area
- 2 most favourable area
- 3 riser
- 4 four sprinklers under consideration

Figure 26 — Most favourable and unfavourable areas of operation in a looped pipe layout

13.4.4 Minimum sprinkler discharge pressure

The pressure at the hydraulically most unfavourably situated sprinkler, when all the sprinklers in the area of operation are in operation, shall be not less than that required to achieve the density specified in 13.4.1 or the following, whichever is the higher:

- 0,70 bar in LH;
- 0,35 bar in OH;
- 0,50 bar in HHP and HHS except for in-rack sprinklers;
- 1,00 bar for K 115 in-rack sprinklers;
- 2,00 bar for K 80 in-rack sprinklers.

13.4.5 Minimum pipe diameters

The pipe diameter shall not be less than as shown in Table 36.

Table 36 — Minimum pipe diameters

Risk	Diameter mm
LH	20
OH and HH horizontal and upright pipe connecting one sprinkler having a K-factor not greater than 80	20
All others	25

Pipe diameters on the installation side of the control valve set might decrease only in the direction of water flow, except in the case of grid and loop configurations.

Upright sprinklers shall not be connected to any pipe with a diameter greater than 65 mm, or 50 mm if lagged. Pendent sprinklers shall not be directly connected to any pipe with a diameter greater than 80 mm. For larger diameters an arm pipe shall be fitted so that the distance from the sprinkler deflector to the edge of the main pipe is not less than 1,5 times the diameter of this pipe.

14 Sprinkler design characteristics and uses

14.1 General

NOTE This standard covers only the use of the types of sprinkler specified in EN 12259-1.

Only new (i.e. unused) sprinklers shall be used. They shall not be painted except as allowed by EN 12259-1. They shall not be altered in any respect or have any type of ornamentation or coating applied after dispatch from the production factory, except as specified in 14.9.

14.2 Sprinkler types and application

14.2.1 General

Sprinklers shall be used for the various hazard classes in accordance with Table 37a, and as specified in 14.2.2 to 14.2.4.

Table 37a — Sprinkler types and K-factors for various hazard classes

Hazard class	Design density mm/min	Sprinkler Type	Nominal K-factor
LH	2,25	conventional, spray, ceiling, flush, flat spray, recessed, concealed, and sidewall	57
OH	5,0	conventional, spray, ceiling, flush, flat spray, recessed, concealed, and sidewall	80 or 115
HHP and HHS ceiling or roof sprinklers	≤ 10	conventional, spray	80, 115 or 160
	> 10	conventional, spray	115 or 160
HHS intermediate sprinklers in high piled storage		conventional, spray, and flat spray	80 or 115

14.2.2 Ceiling, flush, recessed and concealed pattern

Ceiling, flush, recessed and concealed sprinklers shall not be installed in OH4, HHP or HHS areas. Sprinklers without fixed deflectors, e.g. with retracted deflectors which drop to the operating position on actuation, shall not be fitted in the following situations:

- a) where the ceiling is more than 45° from the horizontal;
- b) in situations where the atmosphere is corrosive or likely to have a high dust content;
- c) in racks or under shelves.

14.2.3 Sidewall pattern

Sidewall sprinklers shall not be installed in:

- HH installations except for the protection of corridors, cable ducts and columns.
- OH storage areas.
- above suspended ceilings.

They might only be installed under flat ceilings.

14.2.4 Flat spray pattern

Flat spray sprinklers shall be used only in concealed spaces, above suspended open ceilings and in racks.

14.3 Flow from sprinklers

The water flow from a sprinkler shall be calculated from the following formula:

$$Q = K \times \sqrt{P}$$

where:

Q is the flow in litres per minute;

K is the constant given in Table 37a;

P is the pressure in bar.

14.4 Sprinkler temperature ratings

Sprinklers shall be chosen with a temperature rating close to but no lower than 30 °C above the highest anticipated ambient temperature.

In unventilated concealed spaces, under skylights or glass roofs etc., it might be necessary to install sprinklers with a higher operating temperature, up to 93 °C or 100 °C. Special consideration shall be given to the rating of sprinklers in the vicinity of drying ovens, heaters and other equipment, which gives off radiant heat.

NOTE 1 Under normal conditions in temperate climates a rating of 68 °C or 74 °C is suitable.

NOTE 2 Sprinklers are colour coded in accordance with EN 12259-1 to indicate their temperature rating as specified in Table 37b.

Table 37b — colour code for sprinklers

Glass bulb sprinklers		Fusible link sprinklers	
Nominal operating temperature °C	Liquid colour code	Nominal operating temperature within range °C	Yoke arms colour code
57	orange	57 to 77	uncoloured
68	red	80 to 107	white
79	yellow	121 to 149	blue
93	green	163 to 191	red
100	green	204 to 246	green
121	blue	260 to 302	orange
141	blue	320 to 343	black
163	mauve		
182	mauve		
204	black		
227	black		
260	black		
286	black		
343	black		

14.5 Sprinkler thermal sensitivity

14.5.1 General

Sprinklers of different sensitivities shall be used in accordance with Table 38. Where sprinklers are situated in racks, the sprinklers at the ceiling shall have a sensitivity equal to or of slower response than the sprinklers situated in the racks.

Table 38 — Sprinkler sensitivity ratings

Sensitivity rating	In-rack	Ceiling above in-rack sprinklers	Dry systems Pre-action Type A	All others
Standard 'A'	No	Yes	Yes	Yes
Special	No	Yes	Yes	Yes
Quick	Yes	Yes	No	Yes
NOTE When new sprinklers are added to an existing sprinkler installation, it can be necessary to take into account the effect of different sensitivities in order to avoid excessive activations.				

NOTE Most types of sprinkler are rated, in descending order of sensitivity, as one of the following types (see EN 12259-1):

- quick response;
- special response;
- standard response 'A'.

14.5.2 Interaction with other measures

Account shall be taken of possible interaction between sprinkler systems and other measures. Consequently the thermal response of sprinkler systems shall not be inhibited.

The effective functioning of other fire safety measures might depend on the most effective operation of sprinkler equipment, and in such instances the total fire safety measures shall not be impaired. Particular attention shall be given to this aspect when High Hazard systems are involved.

The effective functioning of sprinkler systems depends on the early suppression or control of fire in the early stages. Except when located in racks, sprinklers are normally operated by the flow of hot combustion gases from the fire horizontally across the sprinklers. Consequently, nothing shall interfere with this horizontal flow of combustion gases.

14.6 Sprinkler guards

When sprinklers, other than ceiling or flush sprinklers, are installed in a position at risk of accidental mechanical damage, they shall be fitted with a suitable metal guard.

14.7 Sprinkler water shields

Sprinklers installed in racks, or under perforated shelves, platforms, floors or similar locations, where water from a higher sprinkler or sprinklers might cause wetting close to the bulb or fusible element, shall be fitted with a metal water shield with a minimum diameter of 0,075 m.

Water shields on upright sprinklers shall not be attached directly to the deflector or yoke, and any bracket supports shall be designed so as to minimize obstruction to the sprinkler water distribution.

14.8 Sprinkler rosettes

Rosettes shall be made of metal or thermosetting plastic. Rosettes shall not be used to support ceilings or other structures.

No part of a rosette shall project from the ceiling below the top of the visible portion of the heat sensitive element of the sprinkler.

14.9 Corrosion protection of sprinklers

Sprinklers installed in premises where corrosive vapours are prevalent shall be protected with a suitable corrosion resistant coating applied by the supplier in conformity with EN 12259-1 unless the sprinkler are manufactured from suitably corrosion resistant materials.

The anti-corrosion treatment shall not be applied to sprinkler bulbs.

15 Valves

15.1 Control valve set

Each installation shall have a control valve set in accordance with EN 12259-2 or EN 12259-3.

15.2 Stop valves

All stop valves which could cut off the water supply to the sprinklers shall:

- close in the clockwise direction;
- be fitted with an indicator that clearly shows whether it is in the open or closed position;
- be secured in the right position by a strap and padlock or secured in an equivalent manner.

Stop valves shall not be installed downstream of the control valve set except as specified in this standard. In order to facilitate testing and maintenance, a stop valve might be installed downstream of the control valve if monitored.

15.3 Ring main valves

Where sprinkler systems are fed by a ring main supply pipe arrangement on the premises, stop valves shall be installed to isolate the ring into sections, in such a way that no section shall include more than 4 control valve sets.

15.4 Drain valves

Drain valves shall be fitted as specified in Table 39 to allow drainage from pipework as follows:

- a) immediately downstream of the control valve set or of its downstream stop valve if fitted;
- b) immediately downstream of any subsidiary alarm valve;
- c) immediately downstream of any subsidiary stop valve;
- d) between a dry pipe or subsidiary control valve set and any subsidiary stop valve installed for testing;
- e) any pipe, with the exception of drop pipes to single sprinklers in a wet installation, which cannot be drained through another drain valve.

The valves shall be fitted at the lower end of the pipework and sized as specified in Table 39. The outlet shall be no more than 3 m above the floor and shall be fitted with a suitable plug.

Table 39 — Minimum size of drain valves

Valve principally draining:	Minimum diameter of valve and pipe mm
LH installation	40
OH or HHP or HHS installation	50
Subsidiary installation	50
A zone	50
Trapped distribution pipes, diameter ≤ 80	25
Trapped distribution pipes, diameter > 80	40
Trapped range pipes	25
Trapped pipework between dry or subsidiary alarm valve and a subsidiary stop valve installed for testing purposes	15

15.5 Test valves

15.5.1 Alarm and pump start test valves

15 mm test valves shall be fitted, as appropriate, to test the following:

- a) the hydraulic alarm and any electric alarm pressure switch by drawing water from the immediate downstream side of the following:
 - a wet alarm valve, and any downstream main stop valves;
 - an alternate alarm valve;
- b) the hydraulic alarm and any electric alarm pressure switch by drawing water downstream of the main water supply stop valve and from the upstream side of:
 - an alternate alarm valve;
 - a dry pipe alarm valve;
 - a pre-action alarm valve.
- c) any water flow alarm switch installed downstream of the control valve set by drawing water downstream of the water flow alarm;
- d) an automatic pump starting device;
- e) any pump or pressure tank house sprinkler alarm flow switch installed upstream of the control valve set.

15.5.2 Remote test valves

A test facility shall be provided, incorporating a test valve with any associated fittings and pipework, delivering a flow equivalent to the discharge from a single sprinkler, connected at the hydraulically most remote location on a distribution pipe.

15.6 Flushing connections

Flushing connections, with or without permanently installed valves, shall be fitted on the spur ends of the installation distribution pipes.

Flushing connections shall be of the same size as the distribution pipe. For pipes bigger than DN40 flushing connections of DN40 might be used, if connected to the lower side of the distribution pipe. Flushing connections shall be fitted with a suitable plug.

It might be desirable in certain cases to fit flushing connections on ranges, e.g. in the form of a blank tee.

In addition to their use for periodic flushing of the pipework, flushing connections might be used to check that water is available and for carrying out pressure and flow tests.

Pipework, which is completely full of water, might be damaged by the increase in pressure due to temperature rises. If complete venting of air in an installation is likely to occur, e.g. in the case of a gridded layout with flushing connections at the extremities, consideration shall be given to the fitting of pressure relief valves.

NOTE Excessive trapped air in a wet pipe installation might cause unacceptable alarm activation time and in the case of gridded pipe configurations, create a hydraulic imbalance. Means could be provided to reduce the volume of trapped air in the installation.

15.7 Pressure gauges

15.7.1 General

Pressure gauge scale divisions shall not exceed:

- a) 0,2 bar for a maximum scale value less than or equal to 10 bar;
- b) 0,5 bar for a maximum scale value greater than 10 bar.

The maximum scale value shall be of the order of 150 % of the maximum pressure.

15.7.2 Water supply connections

Each town main connection shall be fitted with a pressure gauge between the supply pipe stop valve and the non-return valve, ('A' gauge).

Each pump supply shall be fitted with a damped pressure gauge on the supply pipe immediately downstream of the outlet non-return valve and upstream of any outlet stop valve.

15.7.3 Control valve set

A pressure gauge shall be fitted at each of the following locations:

- a) immediately upstream of each control valve set, ('B' gauge);
- b) immediately downstream of each control valve set, ('C' gauge);
- c) immediately downstream of each alternate or dry subsidiary control valve set, but upstream of any stop valve.